

Fundamentals of Management



Seventh
Edition



Ricky W. Griffin
Texas A&M University

© 2014 Cengage Learning. All rights reserved. May not be copied, scanned, or duplicated, in whole or in part, except for use as permitted in a license distributed with a certain product or service or otherwise on a password-protected website for classroom use.

PowerPoint Presentation
by Charlie Cook

PART 3
Organizing

CHAPTER 6

Organization Structure and Design

Chapter Learning Objectives

After studying this chapter you should be able to:



1. Identify the basic elements of organizations.
2. Describe the bureaucratic perspective on organization design.
3. Identify and explain key situational influences on organization design.
4. Describe the basic forms of organization design that characterize many organizations.
5. Identify and describe emerging issues in organization design.

The Basic Elements of Organizing

- Organization Structure and Design
 - The overall set of structural elements that can be used to configure the total organization.
 - A means to implement strategies and plans to achieve organizational goals.
- Job Specialization (Division of Labor)
 - The degree to which the overall task of the organization is broken down and divided into smaller component parts.

Job Specialization

- Benefits of Specialization

- Workers can become proficient at a task.
- Transfer time between tasks is decreased.
- Specialized equipment can be more easily developed.
- Employee replacement becomes easier.

- Limitations of Specialization

- Employee boredom and dissatisfaction with mundane tasks.
- Anticipated benefits of specialization do not always occur.

Alternatives to Job Specialization

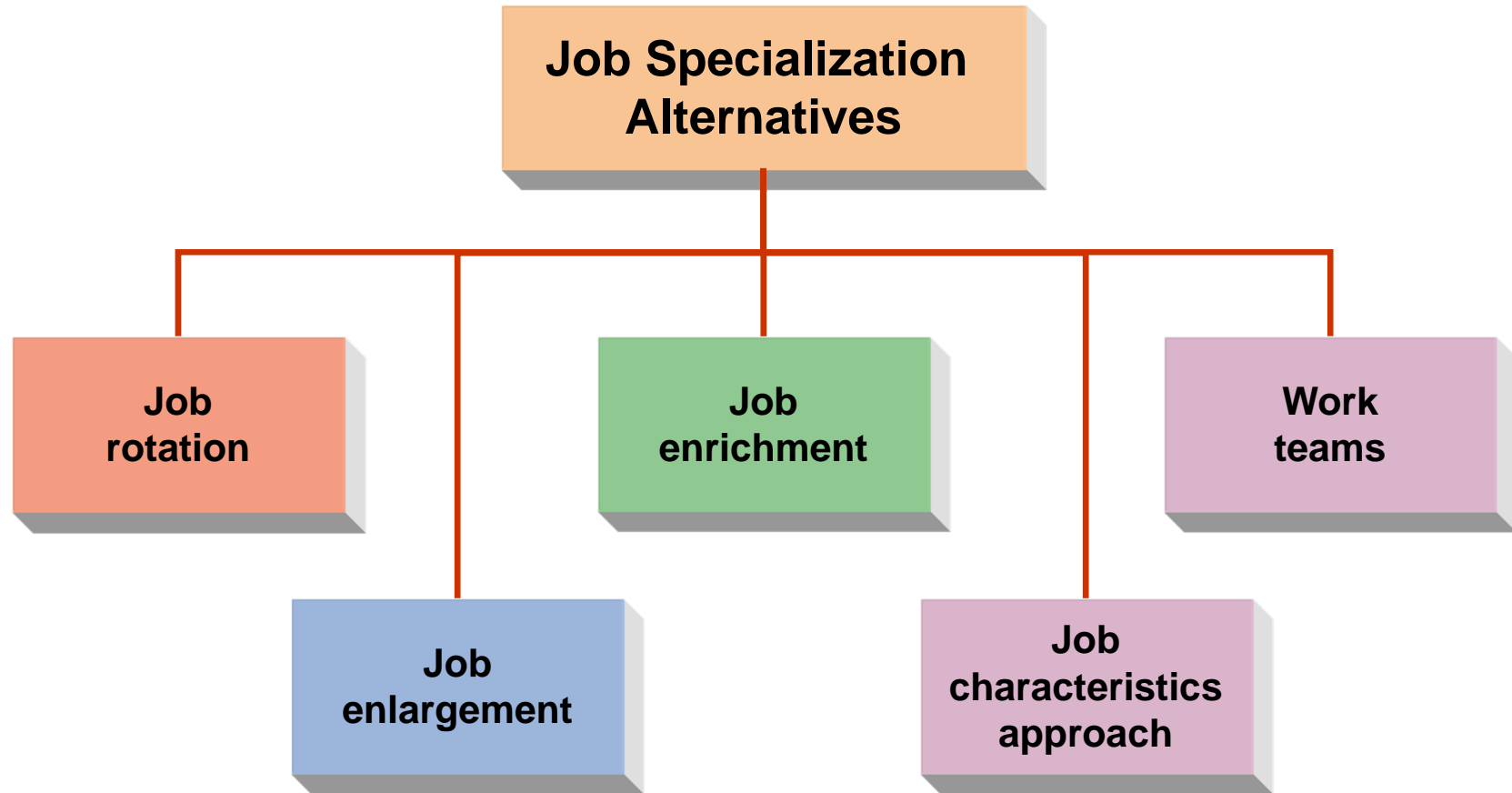

Job Characteristics: Core Dimensions

Skill Variety

The number of tasks a person does in a job

Task Identity

The extent to which the worker does a complete or identifiable portion of the total job

Task Significance

The perceived importance of the task by the worker

Autonomy

The degree of control the worker has over how the work is performed

Feedback

The extent to which the worker knows how well the job is being performed

Growth Need Strength

The desire for people to grow, develop, and expand their capabilities that is their response to the core dimensions

FIGURE 6.1

The Job Characteristics Approach

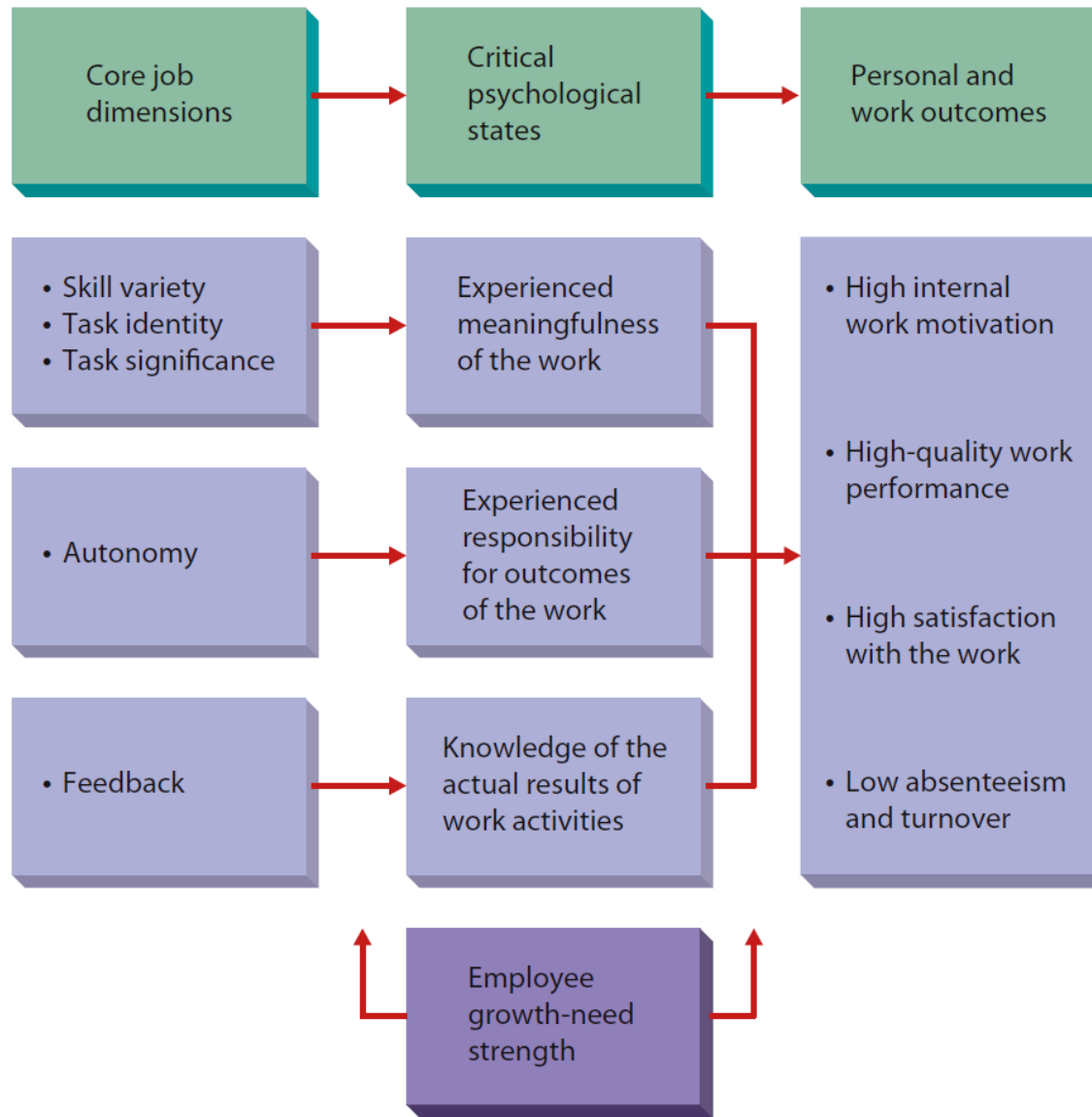

Grouping Jobs: Departmentalization

- Departmentalization
 - The process of grouping jobs according to some logical arrangement.
- Rationale for Departmentalization
 - Organizational growth exceeds the owner-manager's capacity to personally supervise all of the organization.
 - Additional managers are employed and assigned specific employees to supervise.



Common Bases of Departmentalization

By Function

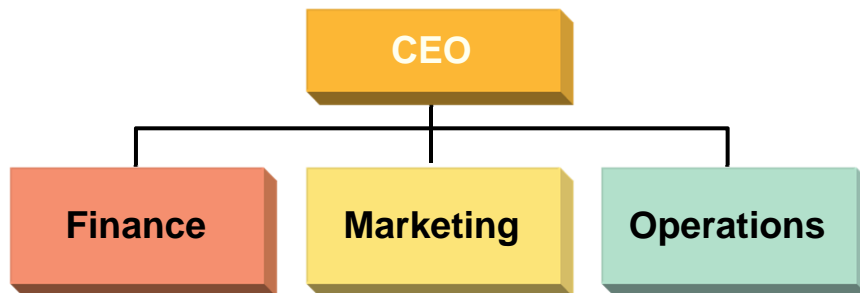

By Product

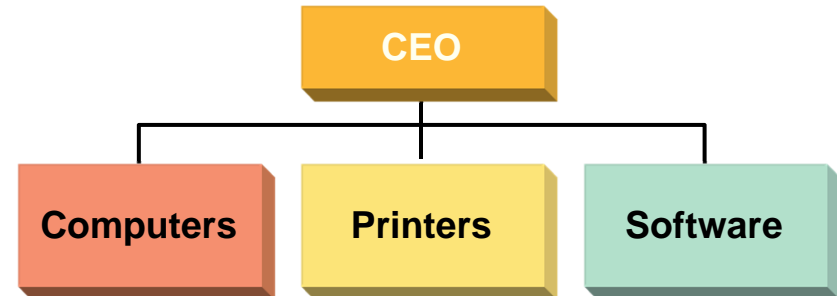

By Customer

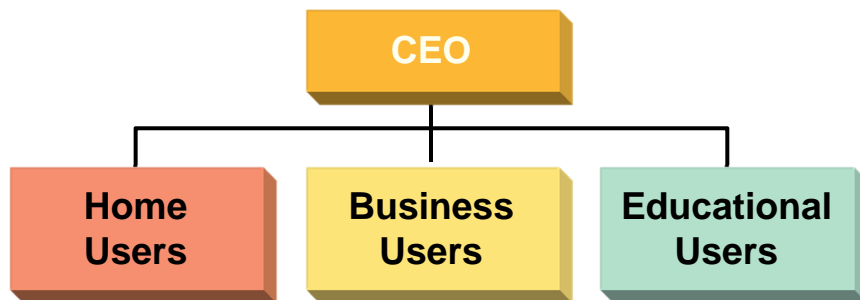

By Location

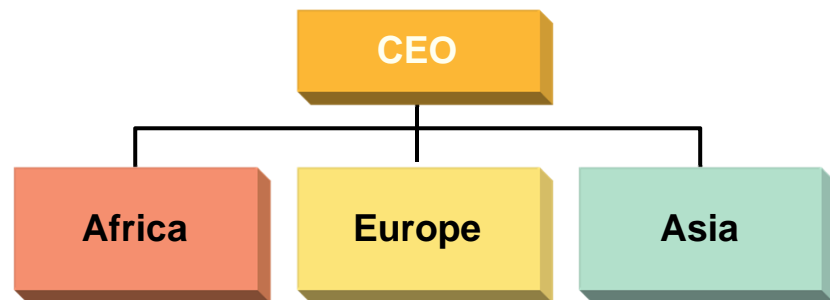

Functional Departmentalization

The grouping of jobs involving the same or similar activities

- **Advantages**

- Each department can be staffed by functional-area experts.
- Supervision is facilitated in that managers only need be familiar with a narrow set of skills.
- Coordination inside each department is easier.

- **Disadvantages**

- Decision making becomes slow and bureaucratic.
- Employees narrow their focus to the department and lose sight of organizational goals/ issues.
- Accountability and performance are difficult to monitor.

Product Departmentalization

The grouping of activities around products or product groups

- Advantages

- All activities associated with one product can be integrated and coordinated.
- Speed and effectiveness of decision making are enhanced.
- Performance of individual products or product groups can be assessed.

- Disadvantages

- Managers may focus on their product to the exclusion of the rest of the organization.
- Administrative costs may increase due to each department having its own functional-area experts.

Customer Departmentalization

The grouping of activities to respond to and interact with specific customers and customer groups

- Advantage
 - Skilled specialists can deal with unique customers or customer groups.
- Disadvantage
 - A large administrative staff is needed to integrate activities of various departments.



Location Departmentalization

The grouping of jobs on the basis of defined geographic sites or areas.

- Advantage
 - Enables the organization to respond easily to unique customer and environmental characteristics.
- Disadvantage
 - Large administrative staff may be needed to keep track of units in scattered locations.

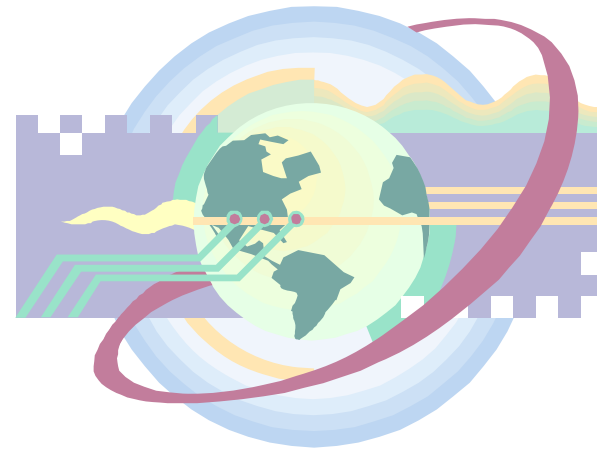

Establishing Reporting Relationships

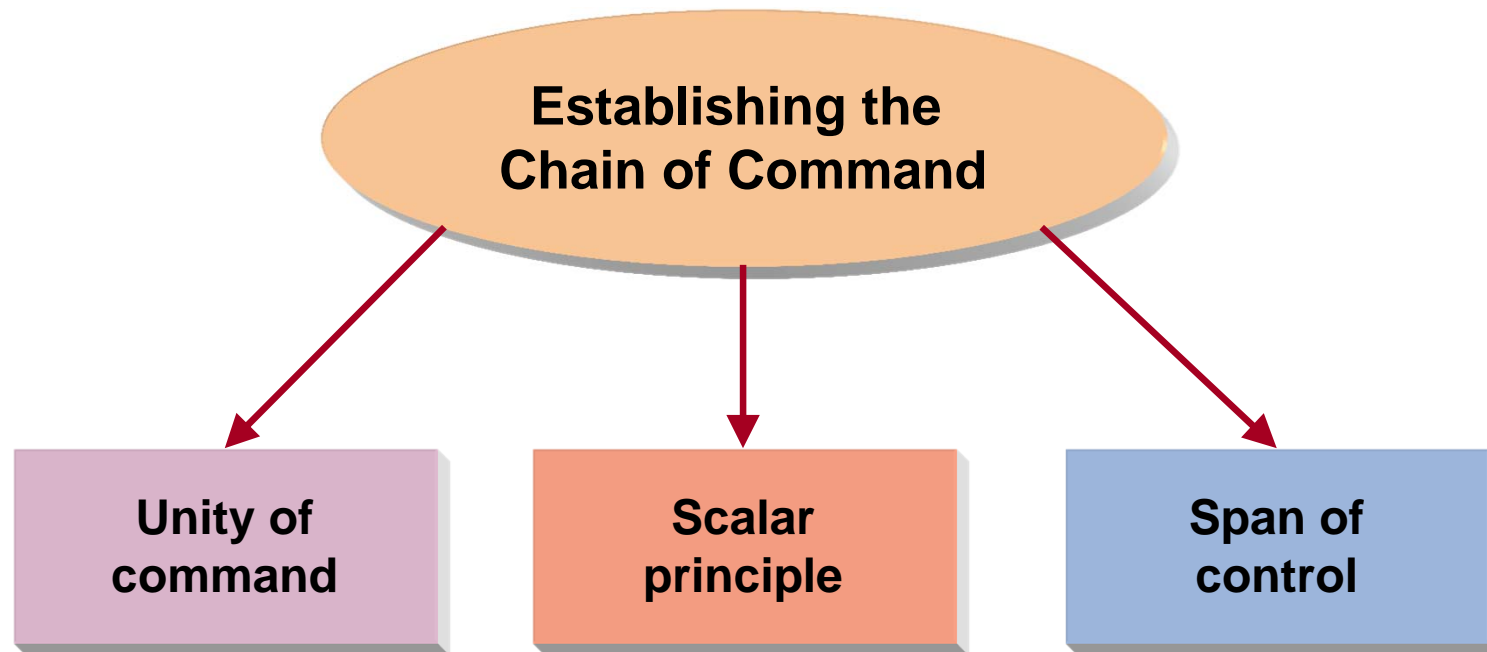

Establishing Reporting Relationships: Tall Versus Flat Organizations

- **Tall Organizations**

- Are more expensive because of the number of managers involved.
- Foster more communication problems because of the number of people through whom information must pass.

- **Flat Organizations**

- Lead to higher levels of employee morale and productivity.
- Create more administrative responsibility for the relatively few managers.
- Create more supervisory responsibility for managers due to wider spans of control.

Tall Versus Flat Organizations

Tall Organization

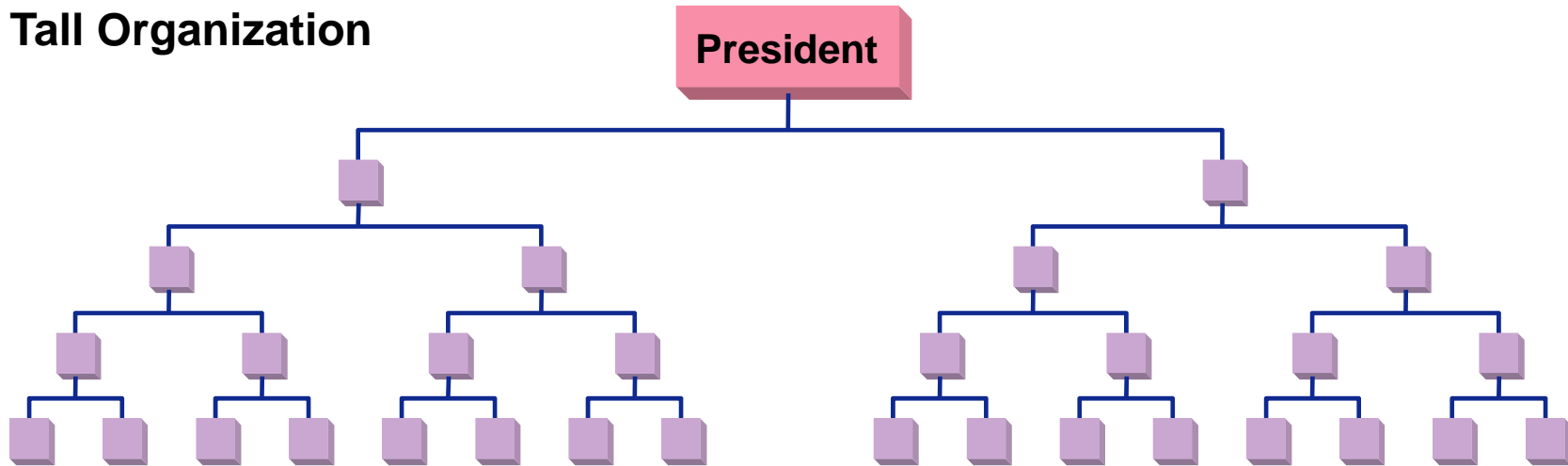

Flat Organization

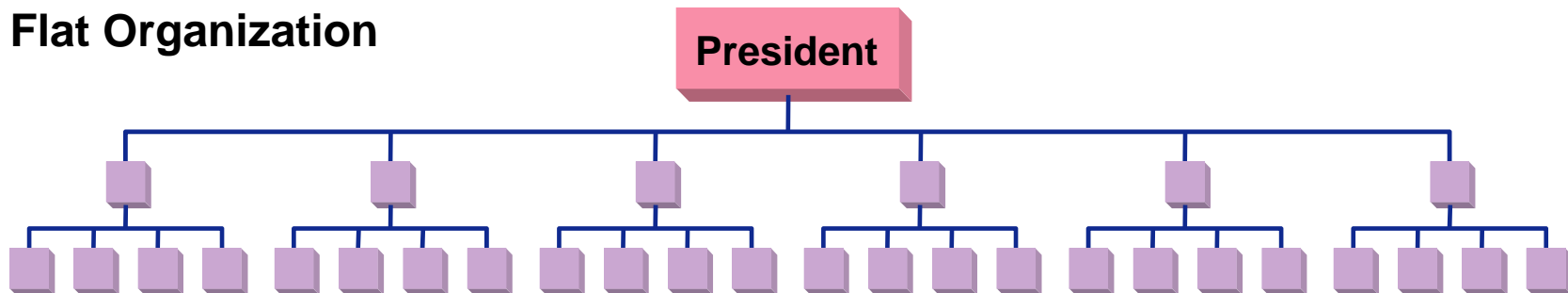

Distributing Authority

- Authority
 - Power that has been legitimized by the organization.
- Delegation
 - The process by which managers assign a portion of their total workload to others.
- Reasons for Delegation
 - To enable the manager to get more work done by utilizing the skills and talents of subordinates.
 - To foster development of subordinates by having them participate in decision making and problem solving.

Steps in the Delegation Process

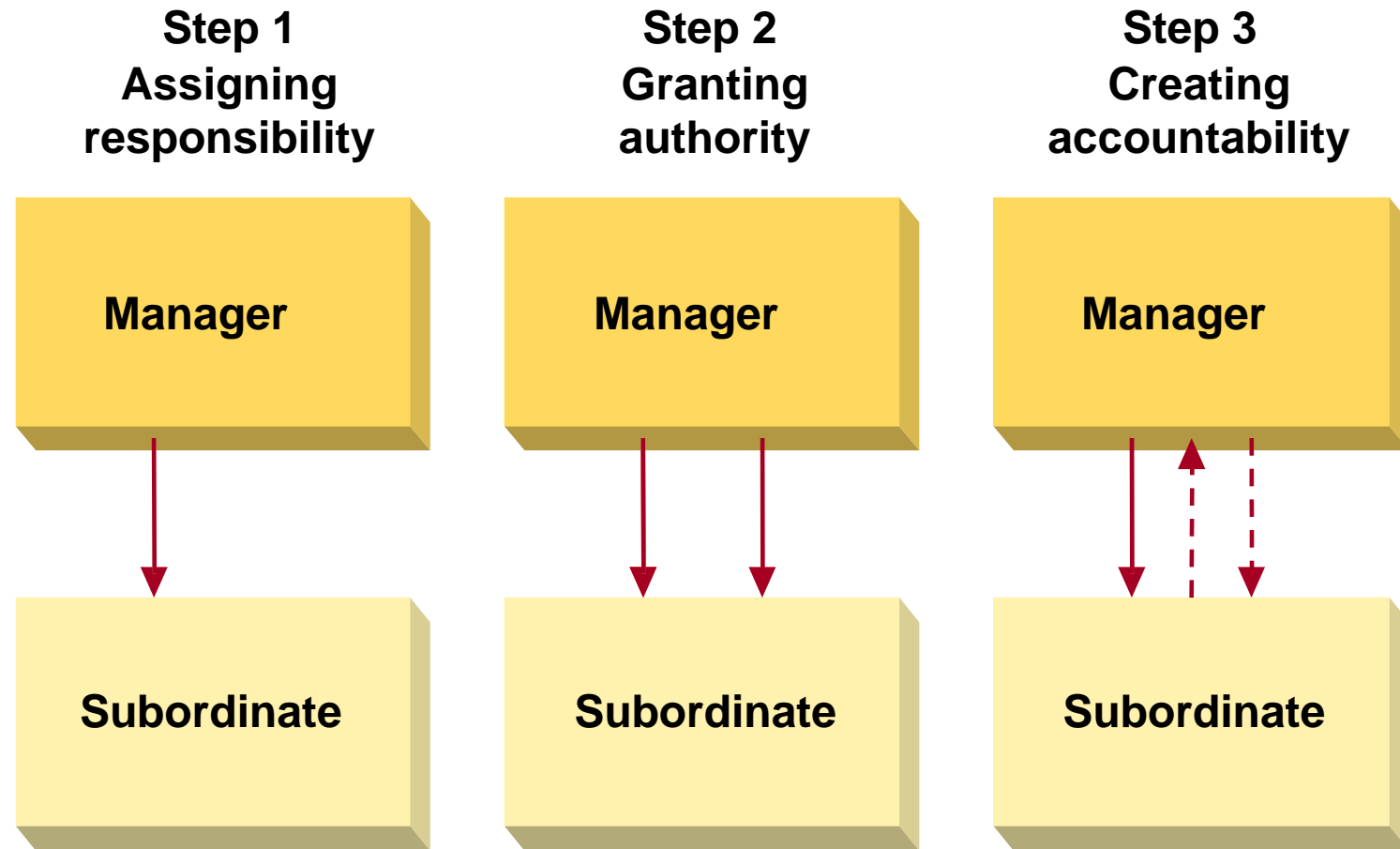

Problems in Delegation

- Manager

- Reluctant to delegate.
- Disorganization prevents planning work in advance.
- Subordinate's success threatens superior's advancement.
- Lack of trust in the subordinate to do well.

- Subordinate

- Reluctant to accept delegation for fear of failure.
- Perceives no rewards for accepting additional responsibility.
- Prefers to avoid any risk and responsibility.

Factors in the Choice of Centralization or Decentralization

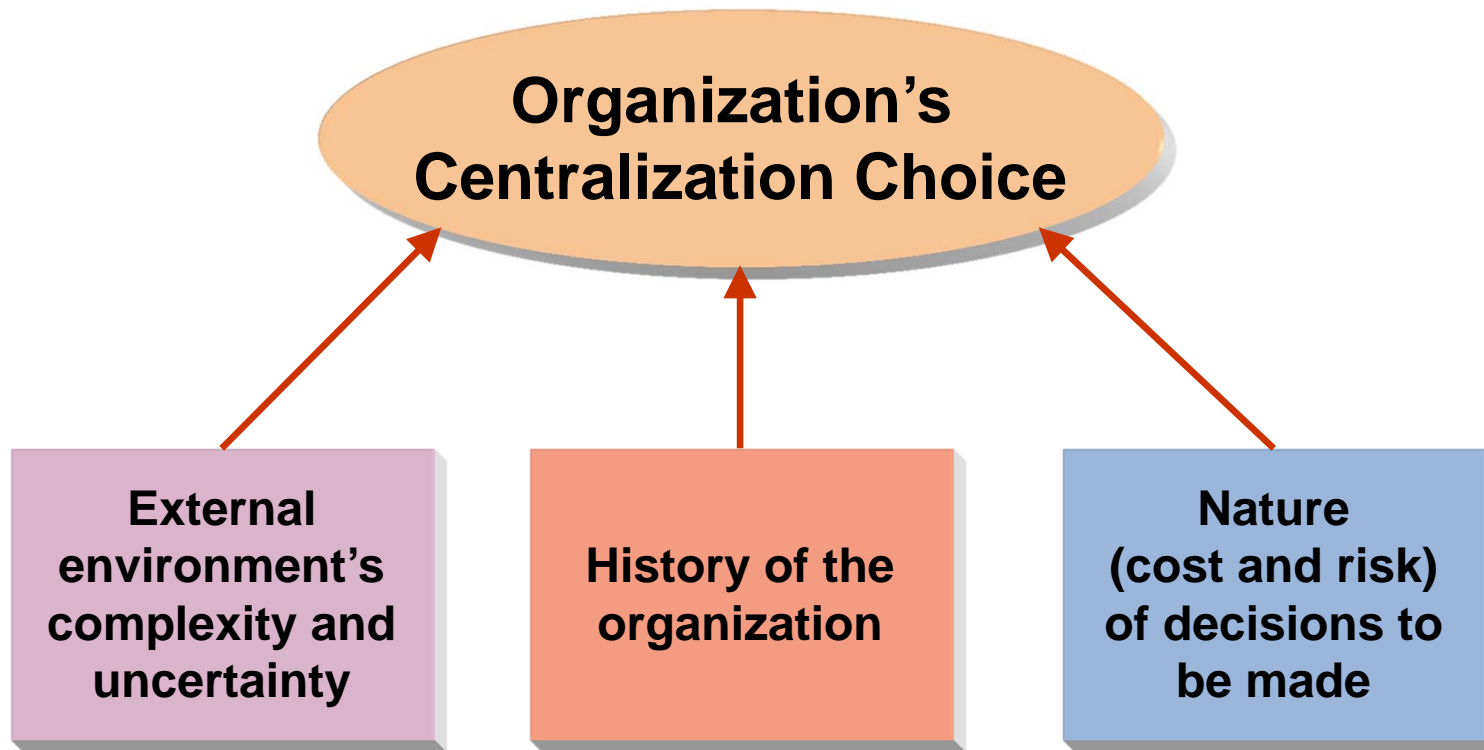

Coordinating Activities

- Coordination
 - The process of linking the activities of the various departments of the organization.
- The Need for Coordination
 - The greater the interdependence of departments and work groups, the greater the need for coordination.



Major Forms of Interdependence

Sequential

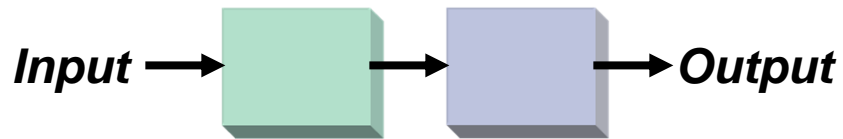

Reciprocal

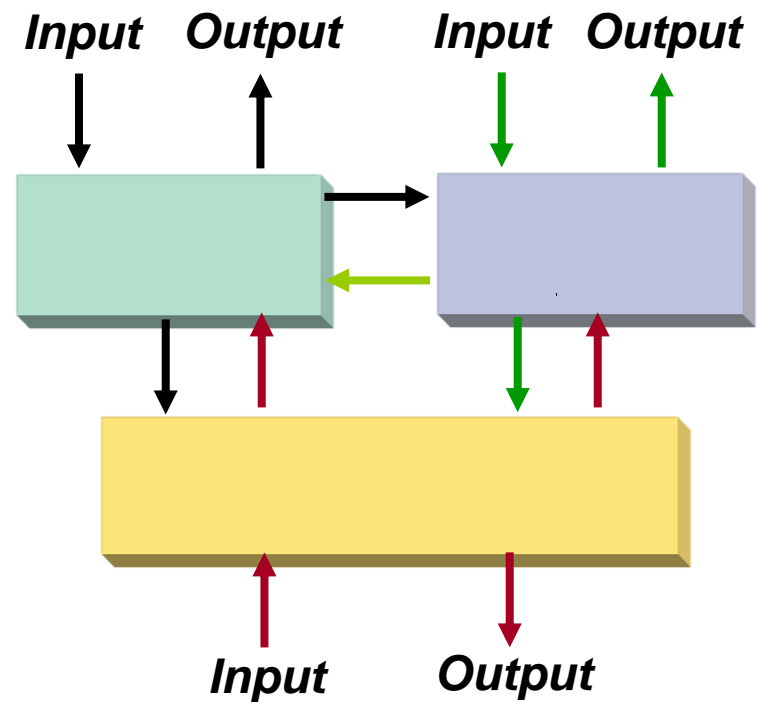

Pooled

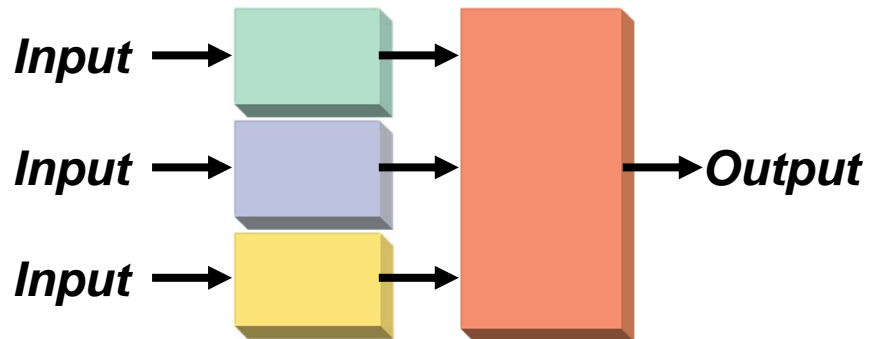

Structural Coordination

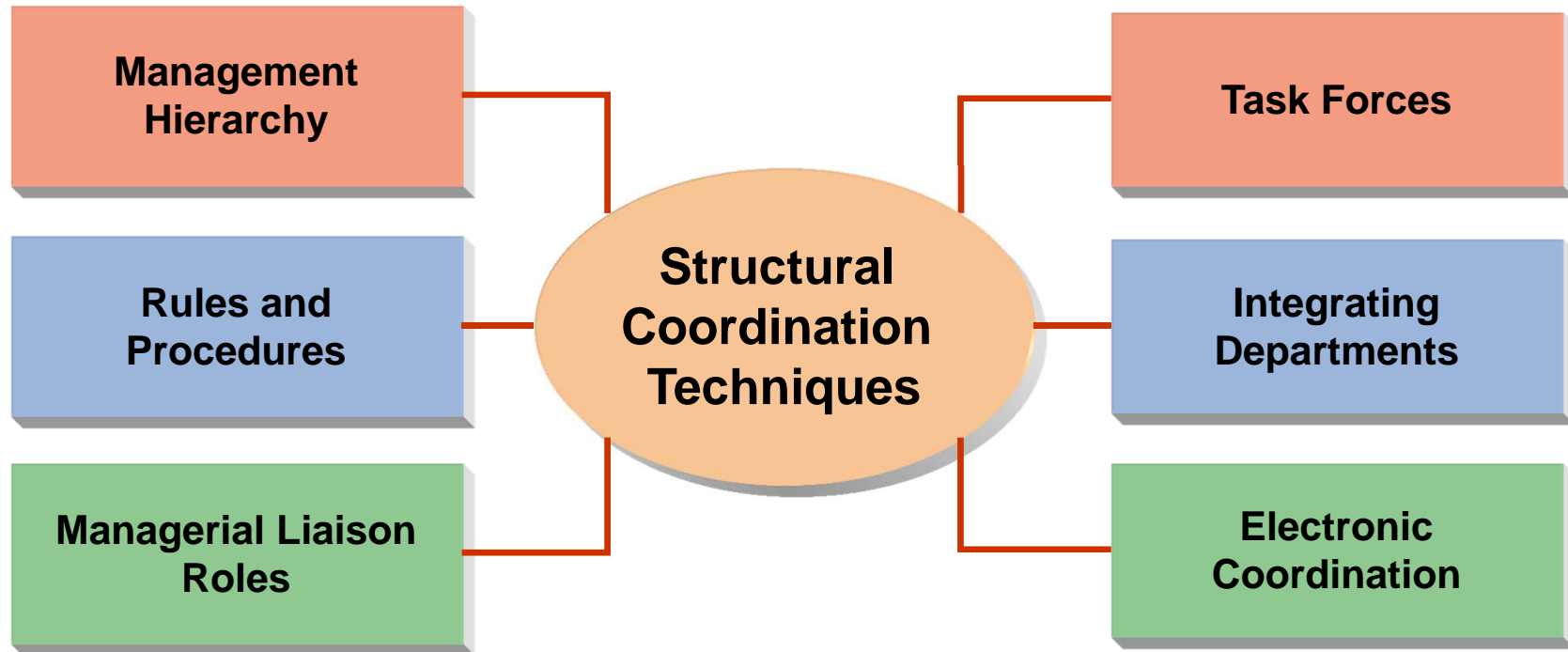

Electronic Coordination Techniques

- Electronic Information Technology
 - E-mail and instant messaging
 - Electronic scheduling to coordinate arrangements for group meetings
 - Local networks structured around a common web-based communication system.
 - Video-conferencing
 - Wireless networks
 - Social networks



The Bureaucratic Model of Organization Design

- Bureaucratic Model (Max Weber)
 - A logical, rational, and efficient organization design based on a legitimate and formal system of authority.
 - Characteristics:
 - A division of labor with each position filled by an expert
 - A consistent set of rules to ensure uniformity in task performance
 - A hierarchy of positions, which creates a chain of command
 - Impersonal management with appropriate social distance between superiors and subordinates
 - Employment and advancement based on technical expertise and employees protected from arbitrary dismissal

Bureaucratic Model

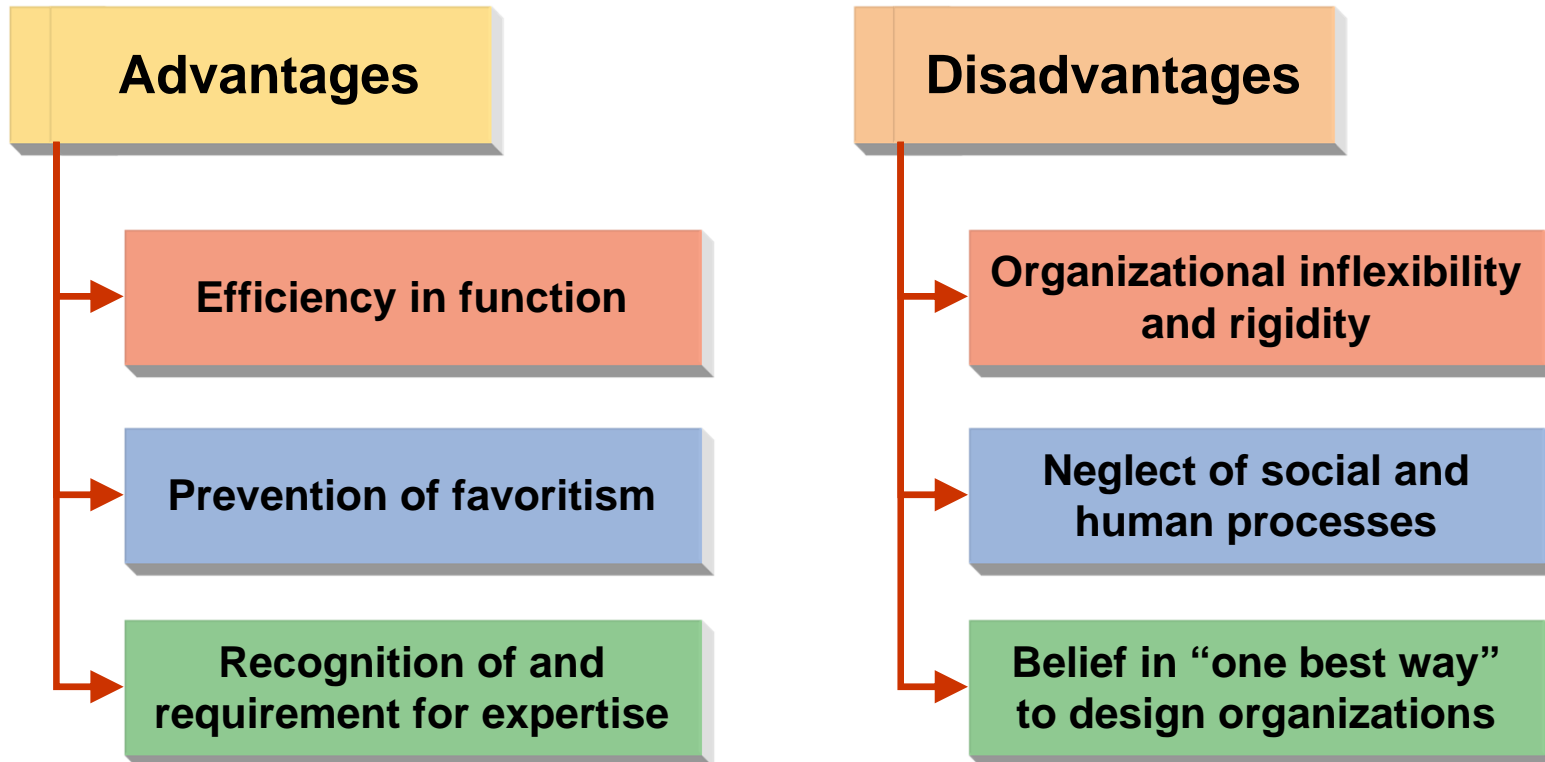

Situational Influences on Organization Design

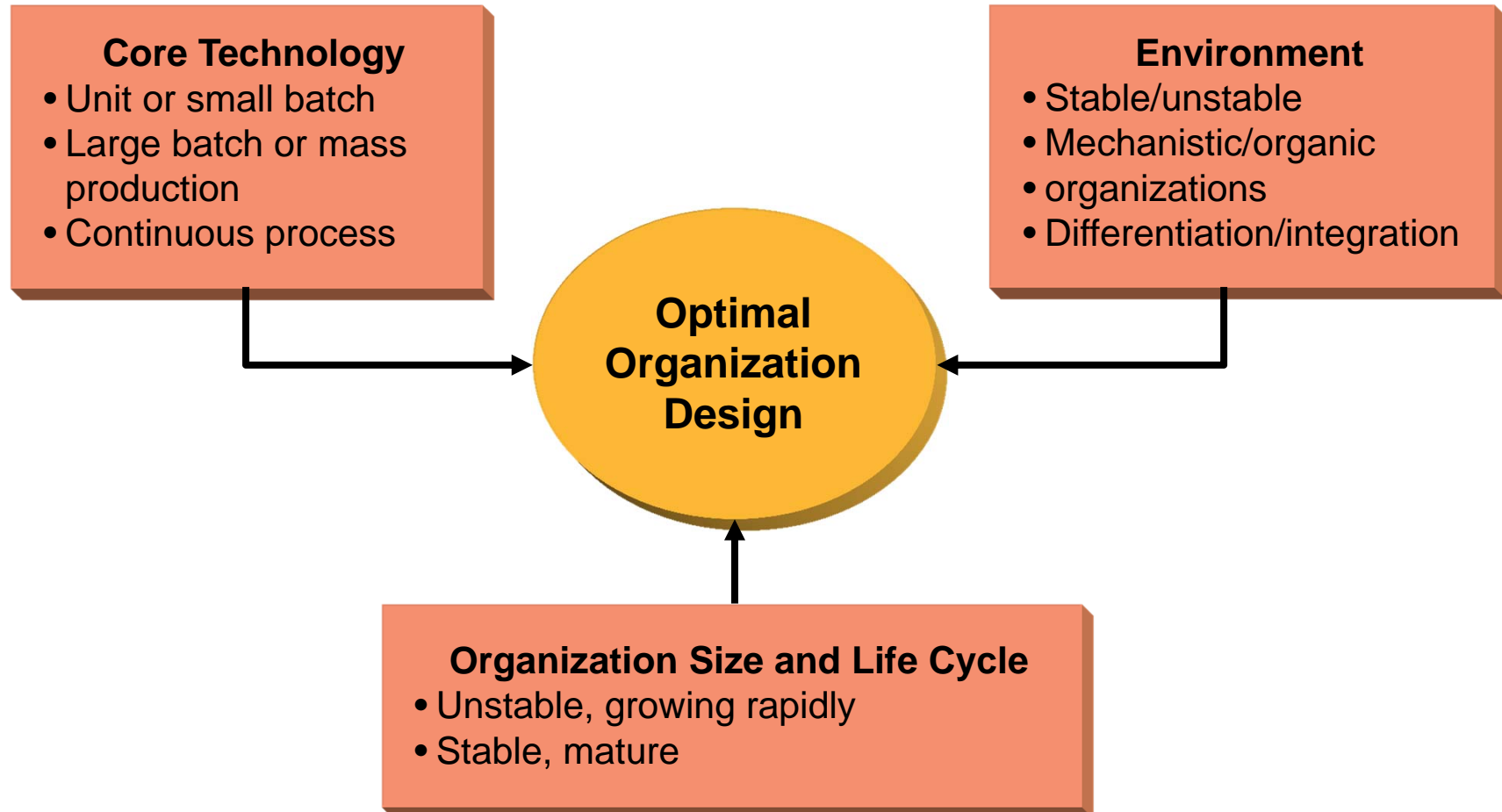

Core Technology and Organization Design

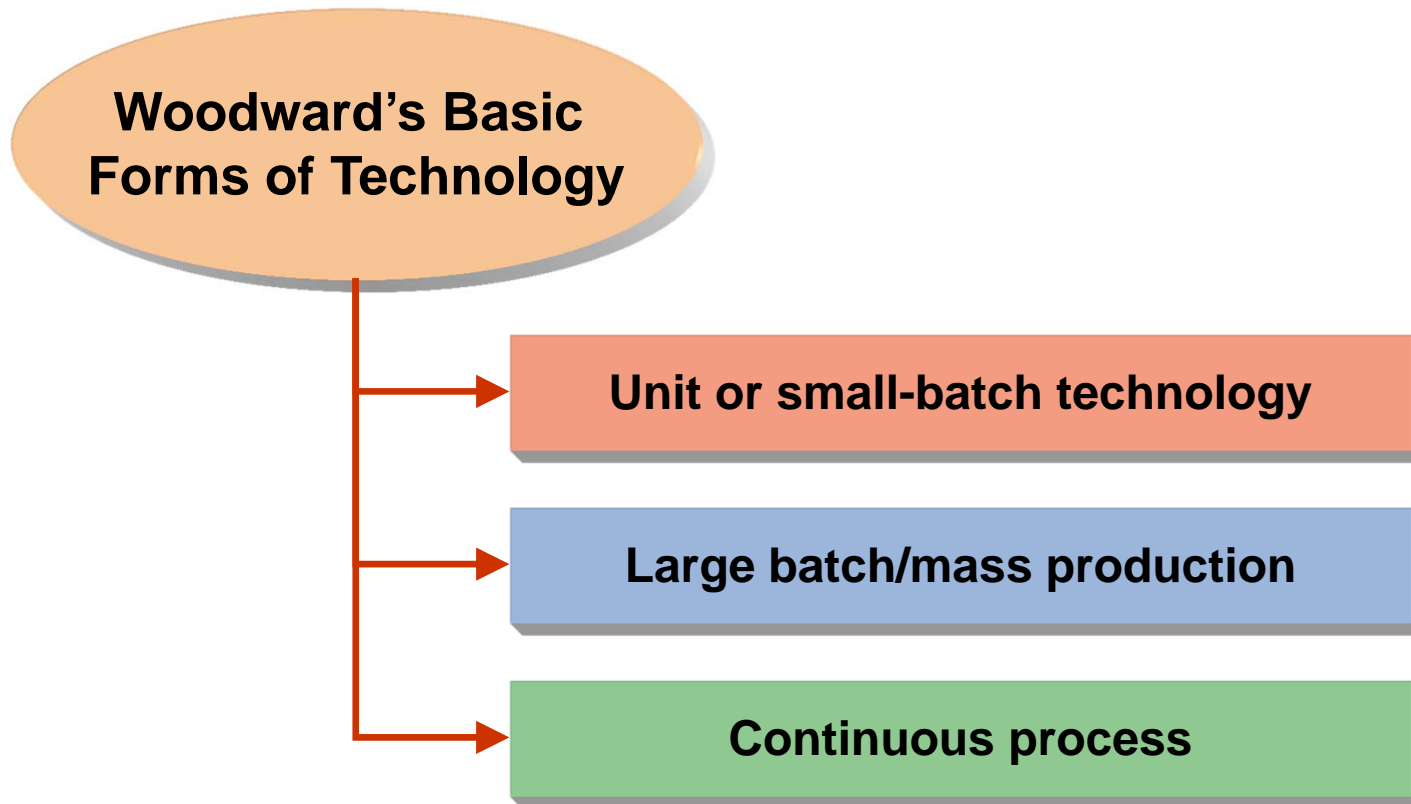

Woodward's Findings

- Unit or small-batch technology and continuous process firms tend to be *organic*—less rigid and more informal.
- Large batch/mass production firms tend to be *mechanistic*—bureaucratic with higher degrees of labor specialization.
- Organizational success was related to the extent to which organizations followed the typical pattern appropriate to their technology.

Environment–Organization Design (Burns and Stalker)

- Research focused on identifying extreme forms of the organizational environment:
 - Stable environments that remain constant over time.
 - Unstable environments subject to uncertainty and rapid change.
- Organization Designs
 - Mechanistic organizations occur most frequently in stable environments.
 - Organic organizations are found in unstable and unpredictable environments.

Differentiation and Integration (Lawrence and Lorsch)

- Predicted environmental factors have differential effects on organization units; affecting the overall design of the organization.
 - Differentiation, the extent an organization is broken into subunits, is associated with stable environments.
 - Integration is the degree to which the various subunits must work together in a coordinated fashion.
 - The degree of differentiation and integration needed by an organization depends on the stability of the environments that its subunits face.

Effects of Size and Life Cycle

- **Organizational Size**

- Defined as the total number of full-time or full-time equivalent employees.

- Research findings:

- Small firms tend to focus on their core technology.
 - Large firms have more job specialization, standard operating procedures, more rules and regulations, and are more decentralized.

- **Organizational Life Cycle**

- The progression of organizations as they grow and mature—birth, youth, midlife, and maturity.

Basic Forms of Organization Design

- Functional or U-form (Unitary) Design
 - Organizational members and units are grouped into functional departments.
 - Requires coordination across all departments.
 - Resembles functional departmentalization in its advantages and disadvantages.
 - Promotes a narrowing functional rather than broader organizational focus
 - Tends to promote centralization
 - Is common in smaller organizations

FIGURE 6.2

Functional (U form) Design for a Small Manufacturing Company

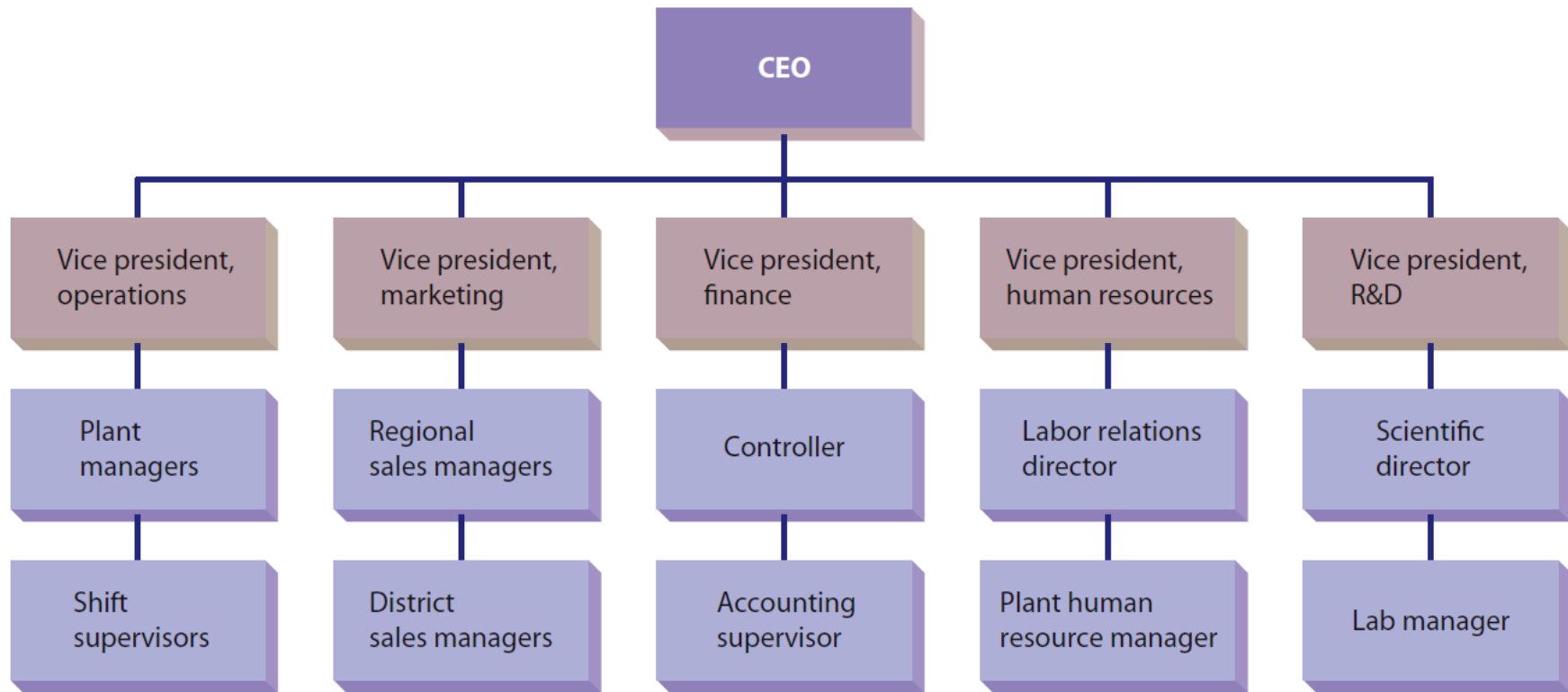

Organization Design (cont'd)

- **Conglomerate or H-form (Holding) Design**
 - Organization consists of a set of unrelated businesses with a general manager for each business.
 - Holding-company design is similar to product departmentalization.
 - Coordination is based on the allocation of resources across companies in the portfolio.
 - Design has produced only average to weak financial performance; has been abandoned for other approaches.

FIGURE 6.3 Conglomerate (H form) Design at Samsung

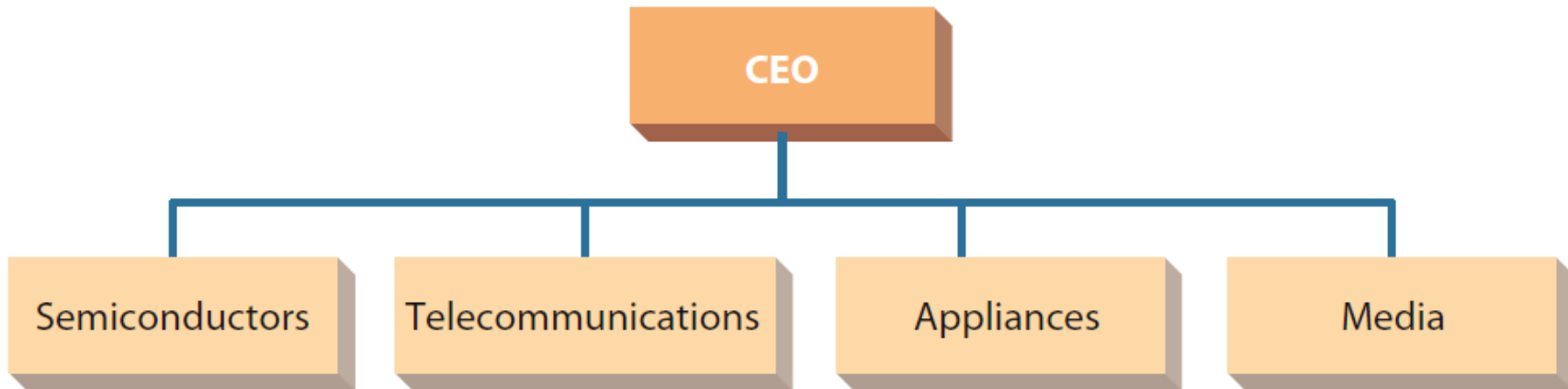

Organization Design (cont'd)

- **Divisional or M-form (Multidivisional) Design**
 - Is based on multiple businesses in related areas operating within a larger organizational framework; following a strategy of related diversification.
 - Activities are decentralized down to the divisional level; others are centralized at the corporate level.
 - The largest advantages of the M-form design are the opportunities for coordination and sharing of resources.

FIGURE 6.4

Multidivisional (M Form) Design at Hilton Hotels

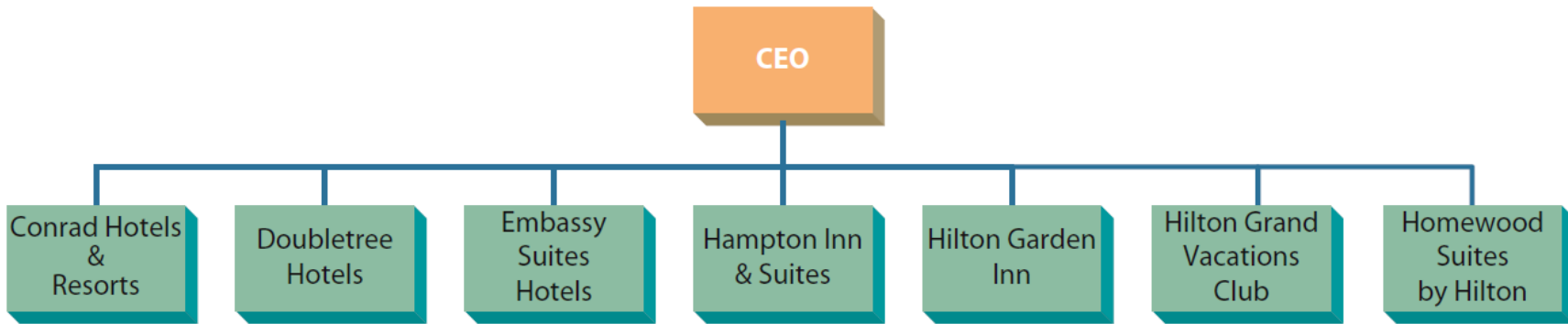

Organization Design (cont'd)

- Matrix Design

- An organizational arrangement based on two overlapping bases of departmentalization.

- A set of product groups or temporary departments are superimposed across the functional departments.
 - Employees in the matrix become members of both their departments and a project team under a project manager.
 - The matrix creates a multiple command structure in which an employee reports to both departmental and project managers.

Organization Design (cont'd)

- Matrix design is useful when:
 - There is strong environmental pressure.
 - There are large amounts of information to be processed.
 - There is pressure for shared resources.

FIGURE 6.5 A Matrix Organization

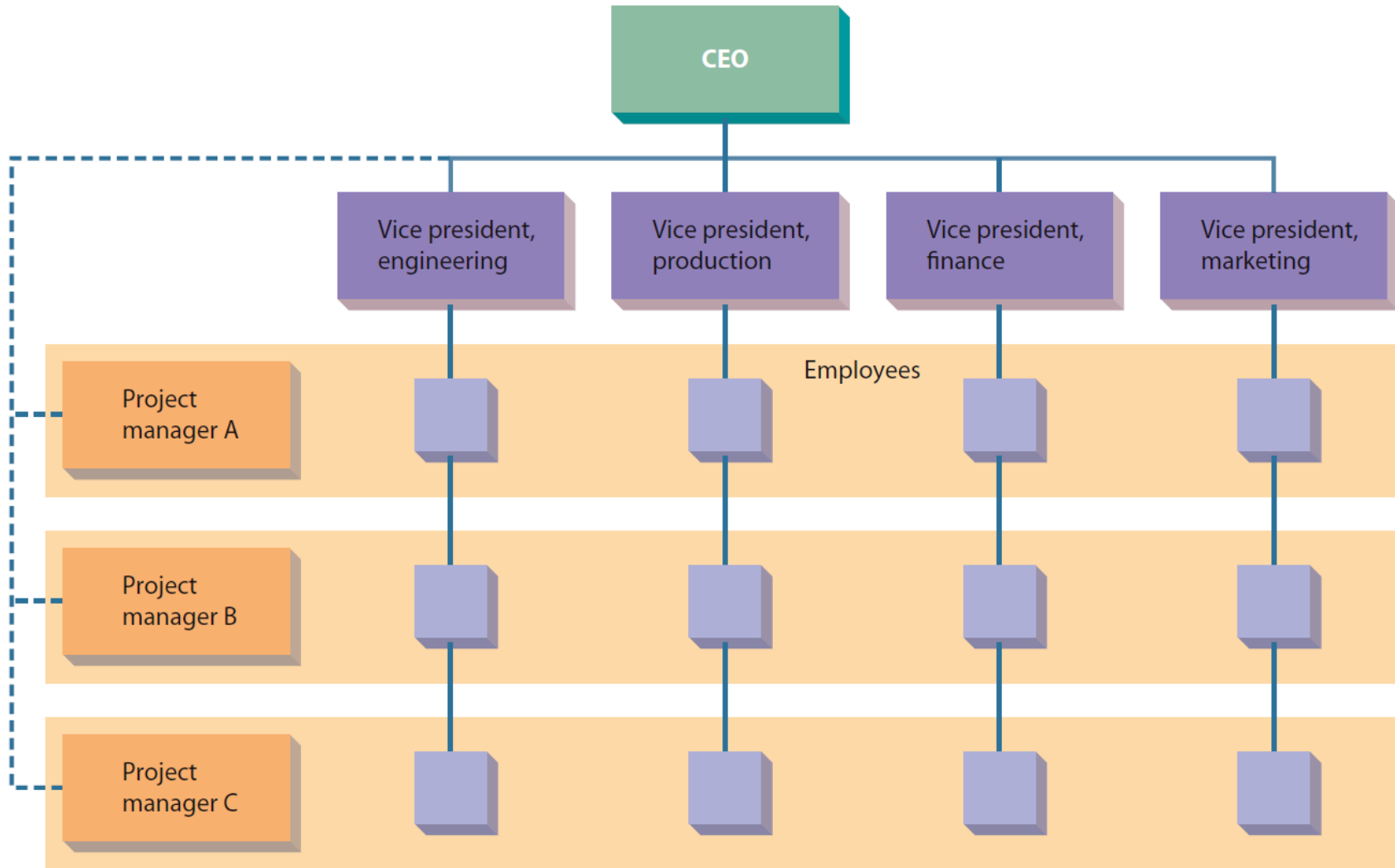

Organization Design (cont'd)

- Matrix Design Advantages

- Enhances organizational flexibility.
- Fosters high motivation and increased organizational commitment.
- Provide opportunity for team members to learn new skills.
- Makes efficient use of human resources.
- Allows team members to serve as bridges to their departments.
- Is a useful vehicle for decentralization.

Organization Design (cont'd)

- Matrix Design Disadvantages

- Employees are uncertain about reporting relationships.
- Managers may view design as an anarchy in which they have unlimited freedom.
- The dynamics of group behavior may lead to slower decision making, one-person domination, compromise decisions, or a loss of focus.
- More time may be required for coordinating task-related activities.

Organization Design (cont'd)

- Hybrid Design

- Is based on two or more organization design forms such as a mixture of related divisions and a single unrelated division.
- Most organizations use a modified form of organization design that permits them to have the flexibility to make strategic adjustments.

The Future of Organization Design

